









LEGENDA:

-  Tablou electric / Electric panel
-  Stîlp, lăvă OL-37, L = 8,00 / Lantern pole OL-37 pipe, L = 8,00 m
-  Corp de iluminat echipat cu lampă cu vapori de sodiu 150W, 230V, 50Hz, class II, IP65
-  Traversare lăvă PVC-KG, SNB / din stîlp în stîlp (de iluminat) ; / Crossing from one lantern pole to another, with PVC-KG tube, SNB;
-  Cablu cu conductoare de cupru de tip CYY-F pentru circuite de iluminat, cu izolație PVC, montat în tub; / Lighting copper conductor cable CYY-F type, PVC insulated, installed in tube;
-  Platbandă OL-Zn 40x4 mm, montată la h=0,80 m față de cota finită a podului / OL-Zn platband 40x4 mm, mounted at a depth of 0.80 m from the bridge's final level ;
-  Electrozi verticali conțineați din OL-Zn, având lungimea de l=2,5 m și diametrul de d=0,06 m, montată la o adâncime de h=0,80 m față de cota finită a terenului / Vertical conductors of OL-Zn with length of l=2,5 m and a diameter of d=0,06 m, mounted at a depth of h=0,80 m from the ground's final level;
-  Cămin de tragere cabluri, 1,20x1,20 m / Cables manhole, 1,20x1,20 m;

K1

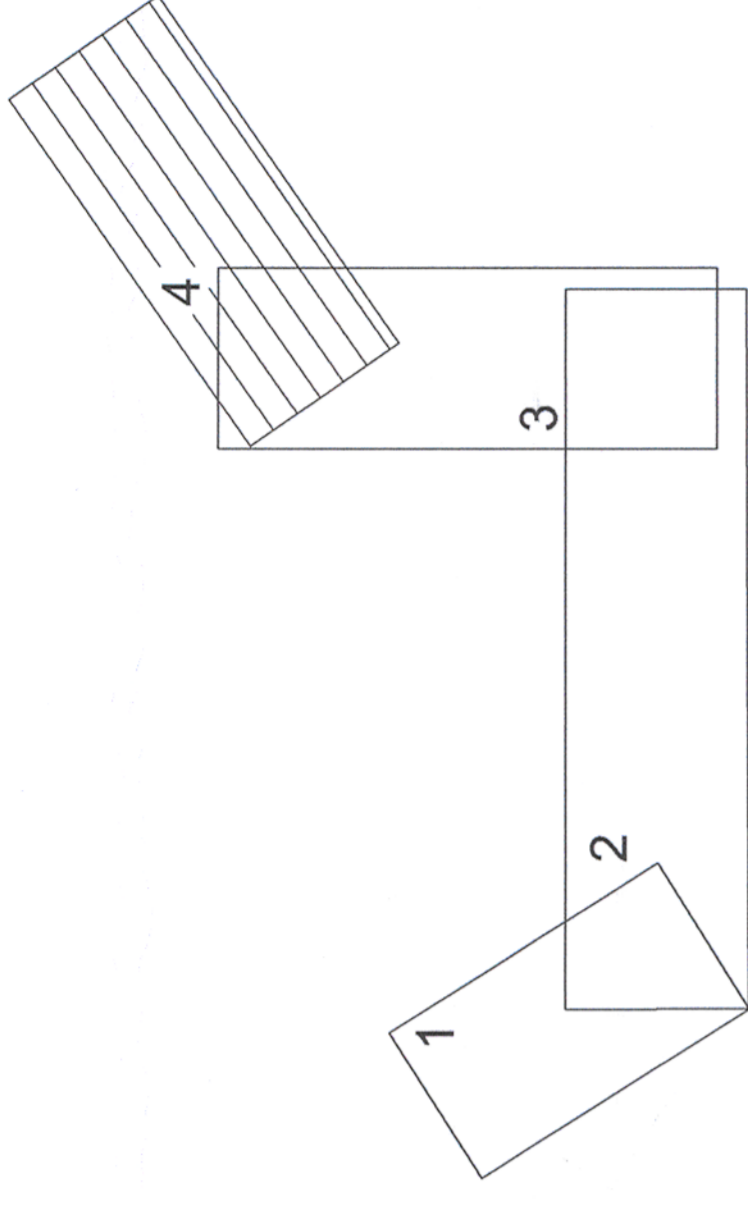
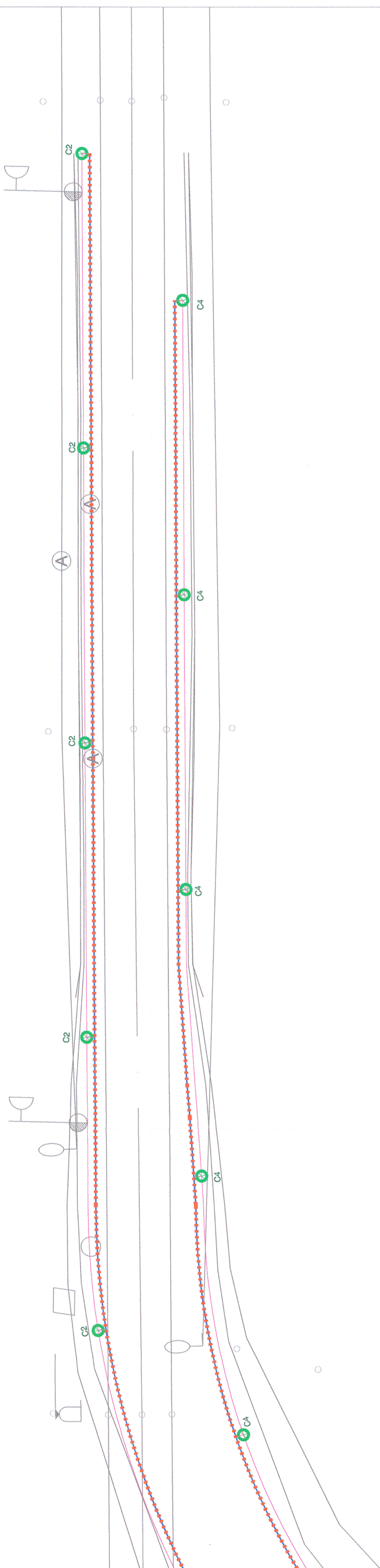

Referat / Expertiza
Report / Expertise
856/24.06.2013.



Verificator / Expert Checker / Expert	Semnătura Signature	Data Date	Semnătura Signature
European Investment Bank	MINISTERUL TRANSPORTURILOR BENEFICIAR / BENEFICIARY : CFR	01.2013	
PROIECTANT / DESIGNER:	PÖYRY	01.2013	
Approbat Approved	Șef de echipă Team leader	C. Teodorescu	
Verificat Verified	Expert Cheie Key Expert	D.A. Stănescu	
Checked			
Subcontractant / Subcontractor	VIOTOP		
Approbat Approved	Adjunct Șef de echipă Deputy Team leader	A.M. Baicu	
Proiectat Designed	Inginer Engineer	M. Ciocitan	
			Proiect 91 35311.1
			Faza / Phase: PTH+CS / TD+TS

Denumire desen / Drawing name:
Iluminat pasaj rutier - Săvăreșin
Săvăreșin - Road passage lighting

Scara / Scale
1:200

Revizia / Revision
1/05.2013

Cod desen / Drawing Code
PT.2B.04.14.IE.14C.004

Nr / No
04/05

"Reabilitarea liniei c.a. Frontieră - Curtici - Simeria, parte componentă a coridorului IV Pan - European, în cadrul proiectului de finanțare de 160 km/h"

"Rehabilitation of the Railway Line Border - Curtici - Simeria, component Part of the IV Pan - European Corridor for the Trains Circulation with maximum speed of 160 km/h"

Section 2 - B: End Y Bărza - End Y Illeu